

A cyclist wearing a black and white jersey and a red helmet is riding a road bike on a paved road inside a tunnel. The tunnel walls are made of dark, layered rock. The lighting is dramatic, with a bright light source from the right illuminating the road and the cyclist, while the rest of the tunnel is in shadow.

DE ROSA

COLLEZIONE - COLLECTION

2017





CARBONIO - CARBON



 DE ROSA

CARBONIO - CARBON

IL CARATTERE DA DOMARE
BALANCE CREATES PERFECTION

.....
#veloce #ambizioso - #speed #ambition
.....

Sulla tavola degli elementi il simbolo del carbonio è la C, come “competitività”. È destinato alla prestazione e alla valorizzazione dell’aerodinamica. Occorre domare la sua leggerezza estrema, approfittare della sua straordinaria resistenza, rispettare la sua rigidità.

Assorbe le vibrazioni e cede energia.

Il telaio in carbonio è ambizioso e frutto di procedimenti che comportano un alto livello di tecnologia applicata ad ogni singola fase di lavorazione.

The letter “C” may stand for Carbon on the periodic table of the elements but when ignited by the catalyst known as De Rosa the product of the equation can only be described as “Competitive”! We take the raw nature of carbon – its extreme lightness, its extraordinary stiffness, its resistance to fatigue – and through a rigorous application of a proprietary technological process we balance it with its softer properties, primarily its ability to absorb vibration and convert it into energy.

This balance creates the perfect equation known to us as a De Rosa carbon frame.

CARBONIO - CARBON



DE ROSA SK PININFARINA LUXURY

L'EVOLUZIONE DELLA SPECIE THE EVOLUTION OF A SPECIES

.....
#lusso #tradizione - #luxury #tradition
.....



La verniciatura mirrow triplo strato, la copertura texture antiscivolo di manubrio e sella, la tecnologia Attrito Zero applicata al cambio, le nuove colorazioni (Nero Caviale, Silver Diamond, Blu Pininfarina), la Sk De Rosa Bike Suitcase e il primo Body-Bike con un'unica cucitura aggiungono esclusività e unicità alla bici che per definizione è la sintesi perfetta tra stile e alte prestazioni. Un prodotto *haute couture* che racconta tutta la creatività di un progetto *All Made In Italy*.

Three layer reflective coating on the paint, the non-slip texture of the handlebars and saddle, the application of Zero Friction technology to the shifters as well as the custom colors – Caviar Black, Silver Diamond, Pininfarina Blue – along with the SK De Rosa bike suitcase and single needle tailored clothing converge to create the perfect blend of elements that define perfectbody/bike uniqueness, exclusivity, style, luxury, and of course, performance.



| SPECIFICHE TECNICHE | TECHNICAL SPECIFICATIONS |

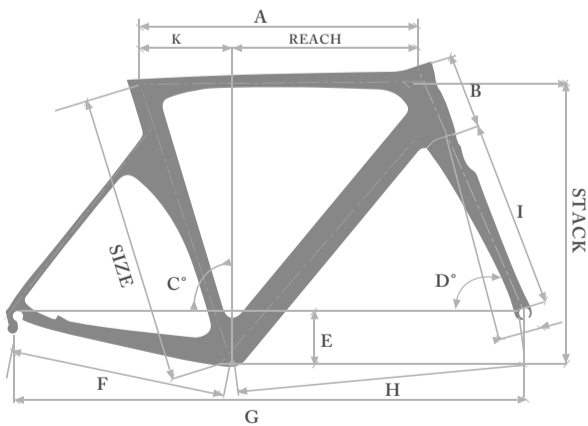

SIZE	REACH	STACK	A	B	C°	D°	E	F	G	H	I	J	K	TRAIL
460	369	478	503	82	74°6'	70°7'	70	396	955	569	368	50	122	65
480	374	496	516	100	74°3'	70°9'	70	396	964	579	368	50	130	63.8
500	379	514	528	118	74°0'	71°2'	70	398	975	587	368	50	138	61.9
520	384	532	541	136	73°7'	71°4'	70	398	984	596	368	50	146	60.7
540	389	550	553	148	73°4'	72°7'	70	400	978	588	368	43	154	59.9
560	394	568	567	166	73°1'	72°9'	70	400	986	596	368	43	163	58.7
580	399	586	580	184	72°8'	73°2'	70	402	996	604	368	43	172	56.8
600	404	604	594	202	72°5'	73°4'	70	402	1004	612	368	43	180	55.6

CARBONIO - CARBON

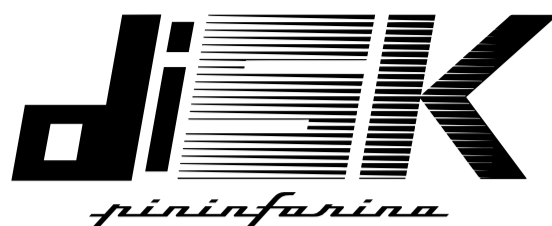

DE ROSA SK PININFARINA DISK

GENIO E REGOLATEZZA INGENUITY AND BALANCE

.....
#versatilità #inarrestabile - #versatility #limitless
.....



Il futuro comincia ora. Non conosce limiti, ama rimodellarli e farli propri. L'impianto frenante a disco viene inserito in gamma grazie alla grande versatilità e capacità di interpretare tutte le sfumature dell'anima del ciclista.

De Rosa SK Pininfarina è un progetto ancora tutto da scoprire che alla tecnicità aggiunge quel pizzico di sana follia di chi ha scritto e diffuso la cultura e l'amore per la bicicletta, guardando sempre al futuro facendo tesoro del passato.

The future is here and now, embodied in the disc brake version of the SK Pininfarina, a frame that knows no limits and can be customized to become one's own! Adding a disc brake system is just one more way in which DeRosa provides the versatility required for cyclist and bicycle to merge the nuances of their individual souls. **DeRosa SK Pininfarina** is a project where technological refinements and distinctions are layered onto the cultural past of cycling to create an irreplaceable experience whose foundation is in the past yet maintains a strong focus on the limitless possibilities of the future.

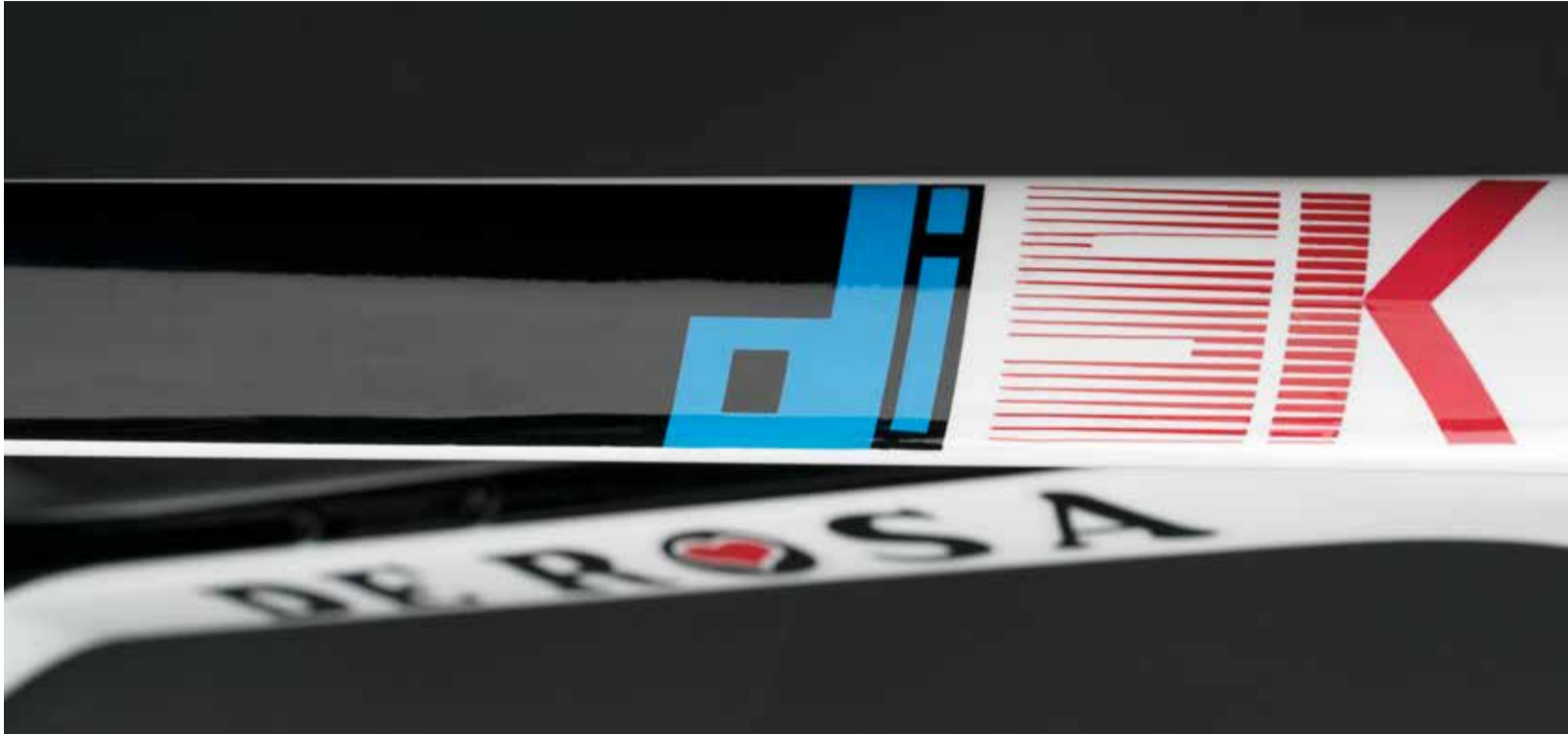

| SPECIFICHE TECNICHE | TECHNICAL SPECIFICATIONS |

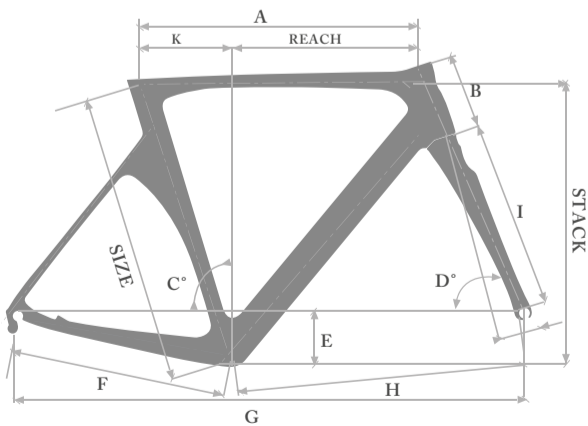

SIZE	REACH	STACK	A	B	C°	D°	E	F	G	H	I	J	K	TRAIL
460	369	478	503	82	74°6'	70°7'	70	396	955	569	368	50	122	65
480	374	496	516	100	74°3'	70°9'	70	396	964	579	368	50	130	63.8
500	379	514	528	118	74°0'	71°2'	70	398	975	587	368	50	138	61.9
520	384	532	541	136	73°7'	71°4'	70	398	984	596	368	50	146	60.7
540	389	550	553	148	73°4'	72°7'	70	400	978	588	368	43	154	59.9
560	394	568	567	166	73°1'	72°9'	70	400	986	596	368	43	163	58.7
580	399	586	580	184	72°8'	73°2'	70	402	996	604	368	43	172	56.8
600	404	604	594	202	72°5'	73°4'	70	402	1004	612	368	43	180	55.6

CARBONIO - CARBON



DE ROSA SK PININFARINA

LA TRADIZIONE PER LA BELLEZZA TRADITION BECOMES BEAUTY

.....
#purezza #stile - #puredesign #style
.....

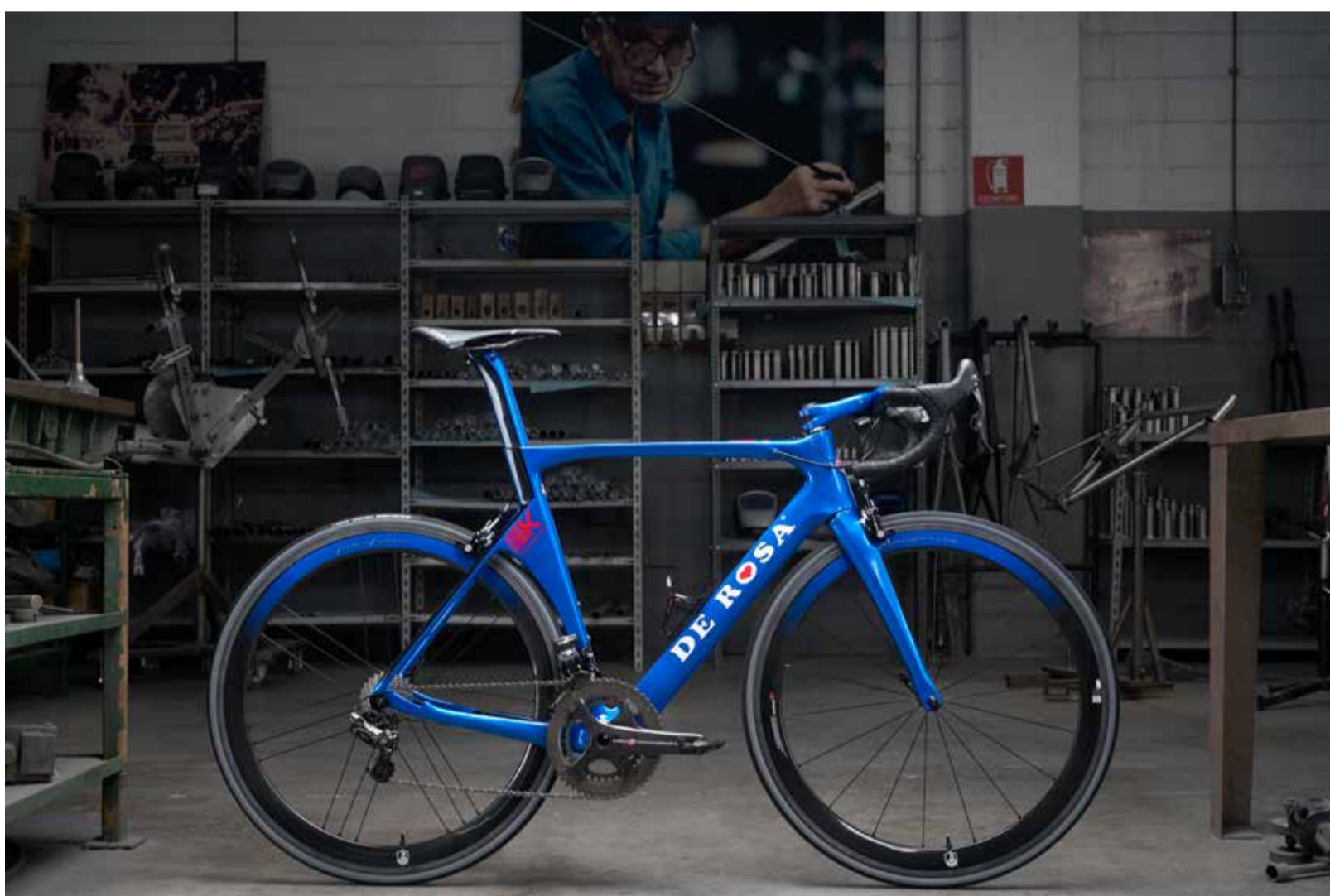

La sfida conquista. Ma le similitudini uniscono. Come le migliori storie d'amore, De Rosa e Pininfarina si sono incontrate condividendo i valori: la tradizione imprenditoriale familiare, la passione per l'innovazione, la continua ricerca di alte performance, l'artigianalità e l'attenzione per il dettaglio, l'amore per il design e per la bellezza. È nata da così la bicicletta che si distingue per le linee eleganti, l'aerodinamicità, la leggerezza e la velocità.

Challenge conquers. But similarities unite. Like all the best love stories, De Rosa and Pininfarina came together through shared values: born from family craftsmanship, the passion for innovation, the continuous search for high-performance, artisanship and attention to detail, and an everlasting adoration of design and beauty. A unison of values that brought to life a lightweight, aerodynamic bicycle with svelte lines and technological perfection.



| SPECIFICHE TECNICHE | TECHNICAL SPECIFICATIONS |

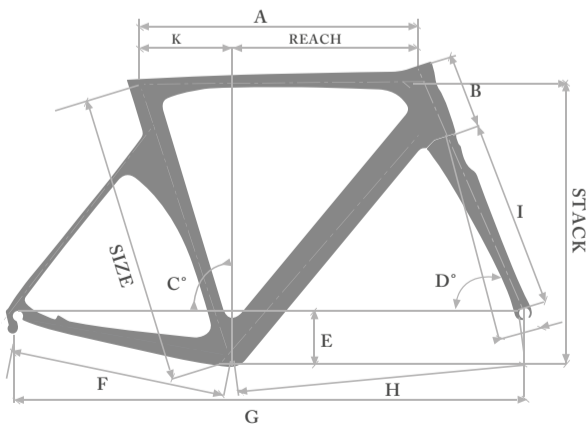

SIZE	REACH	STACK	A	B	C°	D°	E	F	G	H	I	J	K	TRAIL
460	369	478	503	82	74°6'	70°7'	70	396	955	569	368	50	122	65
480	374	496	516	100	74°3'	70°9'	70	396	964	579	368	50	130	63.8
500	379	514	528	118	74°0'	71°2'	70	398	975	587	368	50	138	61.9
520	384	532	541	136	73°7'	71°4'	70	398	984	596	368	50	146	60.7
540	389	550	553	148	73°4'	72°7'	70	400	978	588	368	43	154	59.9
560	394	568	567	166	73°1'	72°9'	70	400	986	596	368	43	163	58.7
580	399	586	580	184	72°8'	73°2'	70	402	996	604	368	43	172	56.8
600	404	604	594	202	72°5'	73°4'	70	402	1004	612	368	43	180	55.6

KING XS

LA PRIMA NON SI SCORDA MAI WE ALWAYS REMEMBER THE FIRST

.....
#contemporanea #confortevole - #contemporary #comfort
.....



King XS è l'up-grade del primo progetto in carbonio di Cusano Milanino che cambia grafiche e si presenta con i nuovi colori Lime e Faema, Grey, Rosso Fuoco, Nero Milano, Bob Black. Pensata e progettata per rispondere alle esigenze dei granfondisti, è una bici altamente performante che unendo la leggerezza all'agilità si configura come un mezzo confortevole e scattante, allo stesso tempo maneggevole e versatile.

Una delle migliori espressioni del carbonio.

King XS evolves from the first-ever carbon project developed by De Rosa in Cusano Milanino and is being presented with completely new graphics and colors: Lime Green, Faema Red, Grey, Fire Engine Red, Matte/Gloss Black and Black. The De Rosa **King XS** was developed specifically to address the needs of the long distance high performance cyclist (think Gran Fondo), perfectly combining lightweight, agile responsiveness, comfort and performance. It is one of the finest expressions of the use of carbon fiber in bike frame development.



| SPECIFICHE TECNICHE | TECHNICAL SPECIFICATIONS |

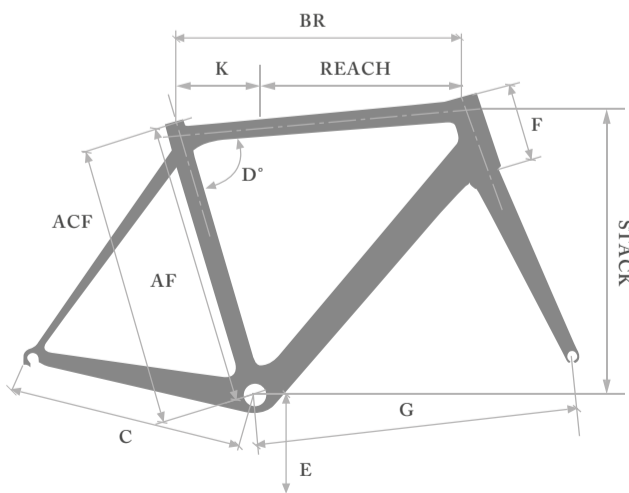

ACF <i>cm</i>	BR <i>cm</i>	C <i>cm</i>	D°	E <i>cm</i>	F <i>cm</i>	G <i>cm</i>	REACH	STACK
41.7	50.5	40.5	75°30'	26.8	11	58	37.2	50.1
45	50.7	40.2	75°	26.8	11	57.3	37	50.4
47	51.9	40.2	75°	26.8	11.7	57.6	38	51.5
49	53.4	40.4	74°40'	26.8	12.6	57.9	38.7	52.6
51	54.5	40.5	73°90'	26.5	13.4	58.3	39	53.5
53	55.5	40.77	73°50'	26.5	14.4	58.6	39.3	54.5

CARBONIO - CARBON

IDOL

LO STILE DA VENERARE STYLE TO REVERE

.....
#animarock #bella - #rockstar #beauty
.....



É bella nella sua estetica. É sacrale nei suoi valori.

É come una star, dall'anima rock.

La **Idol**, con il telaio in carbonio, monta sia i freni a disco sia la soluzione più tradizionale. Nella sua geometria e nella ricercatezza del suo design si esprimono l'esperienza e la storia De Rosa. Sa di mito ed è per chi vuole ottenere performance eccellenti ed è pronto ad accogliere applausi a scena aperta.

The **Idol** is perfectly named, designed with beautiful lines and aesthetics that contain the soul of a rockstar! The carbon frame of the Idol can be mounted with disc or traditional brakes. The geometry and the design are a clear expression of the capability and intent that underlies each and every De Rosa frame. Just like a rockstar, the Idol is capable of mythical performances that cause its audience to give it a standing ovation and spontaneous applause.

 **DE ROSA**



| SPECIFICHE TECNICHE | TECHNICAL SPECIFICATIONS |

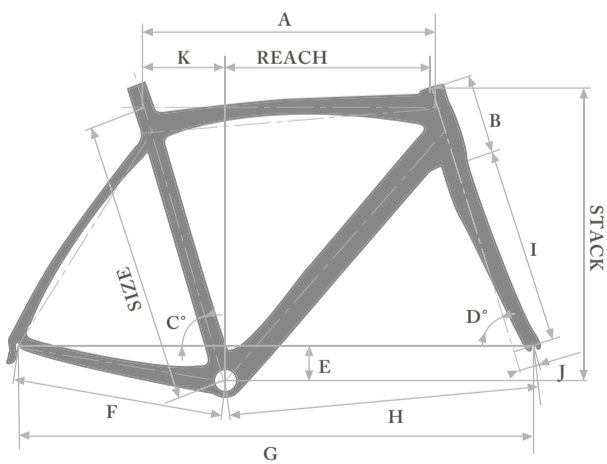

SIZE	A cm	B cm	C°	D°	E cm	F cm	G cm	H cm	I cm	K cm	REACH	STACK
47	51.7	11.1	74°20'	71°	7	40.6	97.3	57.8	36.8	12.8	37.0	50.7
49.5	52.9	11.8	73°90'	72°	7	40.8	97.8	58	36.8	13.7	37.8	51.7
52	54.3	13.5	73°60'	72°60'	7	40.8	97.7	58	36.8	14.5	38.4	53.7
54.5	56	15.4	73°	73°	7	41	98.8	58.8	36.8	15.9	39	55.7
57	57.2	17.5	73°	73°10'	7	41	99.9	59.9	36.8	16.5	39.6	57.7
59.5	58.8	19.5	72°70'	73°30'	7	41.2	101.1	60.9	36.8	17.5	40.2	59.7

PLANET

L'EQUILIBRIO PER TUTTI
PERFECTLY BALANCED
FOR EVERYONE

.....
#libera #accessibile - #balance #accessible
.....



Il telaio in fibra di carbonio attorno al quale scegliere i componenti adatti alle proprie esigenze, per ottenere il prodotto che soddisfa nei contenuti rimanendo accessibile: è questa la **Planet**.

La bicicletta che si presenta con cinque colorazioni e che garantisce la performance. Un successo consolidato, per chi vuole compiere un piccolo passo per pedalare verso ottime prestazioni.

The **De Rosa Planet** is the carbon fiber frame that is accessible to every cyclist offering the opportunity to create their perfect bike and be secure in the knowledge that their personal experience the ultimate in performance, comfort and style.

The **Planet** is offered in a variety of frame sizes and five distinct colors; it is a proven success and the perfect choice for someone taking their first few steps into the incredible world of cycling.



| SPECIFICHE TECNICHE | TECHNICAL SPECIFICATIONS |

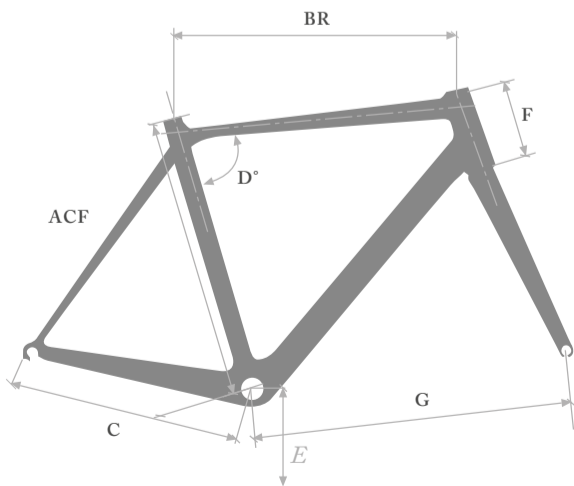

ACF <i>cm</i>	BR <i>cm</i>	C <i>cm</i>	D°	E <i>cm</i>	F <i>cm</i>	G <i>cm</i>
47	51.4	40.6	74°50'	26.8	11	57.4
50	52.5	40.6	74°50'	26.8	12.2	57.7
53	53.8	40.6	74°50'	26.5	14.5	58.3
55	55.5	40.6	73°50'	26.5	16	58.9
58	57	40.9	73°	26.5	19.5	59.9

NICK

LA PRIMA VOLTA THE FIRST TIME

.....
#invitante #fresca - #fresh #myfirstride
.....



Perfetta per chi sale in sella a una De Rosa per la prima volta. Un vero e proprio concentrato di tecnologia à porter, per un approccio moderno, immediato e bike-friendly.

Il tratto graffiante della grafica accompagna le linee pulite di una bicicletta sobria ma di carattere, come il suo nome.

Nick, l'affettuoso nomignolo di Nicholas De Rosa, scritto di getto su un foglio bianco ha conquistato le terre del Sol Levante per la sua freschezza, immediatezza e grande comunicabilità ancor prima di diventare "la prima volta".

The **Nick**, so named using the affectionate name for Nicholas DeRosa, the oldest son in the third generation of De Rosa frame builders, is THE perfect choice of bike for those who ride a DeRosa, or any bike for that matter, for the first time. Nick combines De Rosa technology with a modern look that satisfies both the eye and the rider once he or she mounts the bike. The graphics are derived from the character of the person after whom the bike is named, as are the clean lines of the frame; character and quiet strength that is understood immediately rather than called to our attention. Nick, with its fresh and welcoming look has humbly conquered the land of the Rising Sun.



| SPECIFICHE TECNICHE | TECHNICAL SPECIFICATIONS |

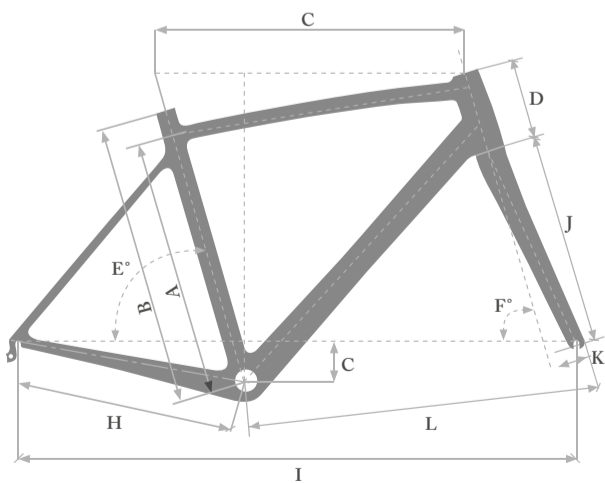

SIZE	A cm	B cm	C cm	D cm	E°	F°	H cm	I cm	J cm	K cm	L cm
462	412	462	515	102,3	74°5'	72°	406	961	368	43	566
480	430	480	531,6	125,6	74°1'	72°2'	406	973	368	43	577
498	448	498	548,4	145	73°7'	72°4'	406	985	368	43	589
522	467	522	565,5	165,3	73°3'	72°6'	406	997	368	43	600
545	485	545	583	182,7	72°9'	73°3'	406	1003	368	43	606,8

TITANIO - TITANIUM



DE ROSA

TITANIO - TITANIUM

LA NOBILTÀ DELLA RESISTENZA A TRADITION OF SUPERIORITY

.....
#nobile #resistente - #nobleness #stiffness
.....

Conosciuto per la sua resistenza e per le sue proprietà meccaniche oltre che alla corrosione e per l'alto rapporto resistenza/peso, richiede un'alta specializzazione per la sua lavorazione.

Per De Rosa racconta un'eccellenza trasmessa di generazione in generazione con passione e dedizione, che fanno di Nicholas De Rosa uno dei più giovani telaisti capaci di modellarlo al mondo. Tutte le biciclette in titanio De Rosa sono grado 9.

The nobleness of titanium is defined by the superiority of its mechanical properties, by its resistance to fatigue and corrosion as well as an extremely high stiffness to weight ratio. Every De Rosa titanium frame is created using Grade 9 titanium, the same titanium used in the manufacture of aircraft hydraulics.

Nicholas DeRosa, recognized as one of the youngest frame builders in the world, carries on the De Rosa legacy and tradition that has defined world class titanium bike frames for three generations.

Solo . . .

SOLO TU, IMMENSO
THE ONE AND ONLY

.....
#orgoglio #assolo - #pride #oneandonly
.....



L'assoluto in De Rosa si chiama **Titanio Solo**. Il telaio che, con le sue linee scrive la storia. Tubazioni over size a triplo spessore, trafilate con la massima precisione, in grado 9 come le minuterie.

Solo perché è unico, perché è esclusivo e *taylor made*, perché significa orgoglio, perché è l'opera d'arte che esce da Cusano Milanino. È la promessa d'amore, passione, tecnologia, materia, filosofia e cultura della bicicletta.

The utmost in De Rosa frames is called **Titanio Solo** – the One and Only. The frame, with lines written in history, triple butted oversizing tubing that has been cold drawn with the utmost precision in Grade 9 Titanium. The **Titanio Solo** is unique, special, and made to measure for the discerning cyclist. TitanioSolo is a work of art made directly by the artisan frame builders in Cusano Milanino; pride describes both their craftsmanship and your ownership. It is the promise of all the feelings and components that are the foundation of the cycling lifestyle: love, joy, passion, technology, unique materials, philosophy and culture.



| SPECIFICHE TECNICHE | TECHNICAL SPECIFICATIONS |

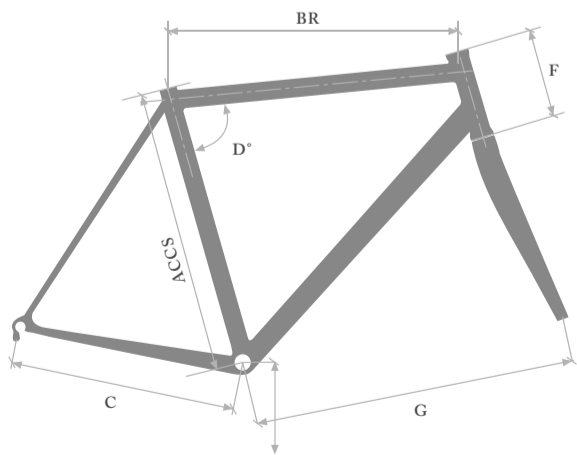

SLOPE ACCS	ACCR <i>cm</i>	BR <i>cm</i>	C <i>cm</i>	D°	F <i>cm</i>	G <i>cm</i>
44	48	51	39,8	76°	104	58
45	49	52	40.10	75°88'	111	58
45	50	52.5	40.10	75°15'	122	58.1
46	51	53	40.20	75°	130	58.1
47	52	53.5	40.40	74°30'	137	58.2
48	53	54	40.45	74°15'	146	58.3
49	54	54.5	40.55	74°	154	58.4
50	55	55	40.65	73°45'	165	58.6
51	56	56	40.85	73°10'	173	59
52	57	56.5	40.90	73°	181	59.2
53	58	57.5	40.90	73°	192	60.2
54	59	58	41.00	72°45'	202	60.4
55	60	58.5	41.10	72°30'	212	60.6

TREDUECINQUE

IL RICONOSCIMENTO DELLA MATERIA PRIMA RECONNECTING WITH ONE OF OUR PRIMARY MATERIALS

.....
#unica #eterna - #unique #timeless
.....



All'inizio degli anni '90 De Rosa decide di utilizzare il titanio come materia nobile per realizzare il nuovo progetto **Tredecinque**, che consacra la capacità manifatturiera delle officine De Rosa. Un unico modello diventato oggetto di culto che cambia look nel tempo, ma non la sua unicità che va oltre le mode.

La dimostrazione che dedizione, pazienza e tempo posso modellare anche un materiale eccezionalmente resistente rendendo estrema la piacevolezza di pedalata.

During the early 90's De Rosa embarked on what has become a multi-generational voyage with Titanium in order to perfect the frame known as **Tredecinque** by dedicating a significant portion of the research, development and manufacturing capacity facilities at the De Rosa office to this unique project. **Tredecinque** has developed a cult following despite the changes required by its evolution. The dedication, patience and time required to work with this incredibly strong material also helps us instill the joy and beauty of the ride into every frame we create!



| SPECIFICHE TECNICHE | TECHNICAL SPECIFICATIONS |

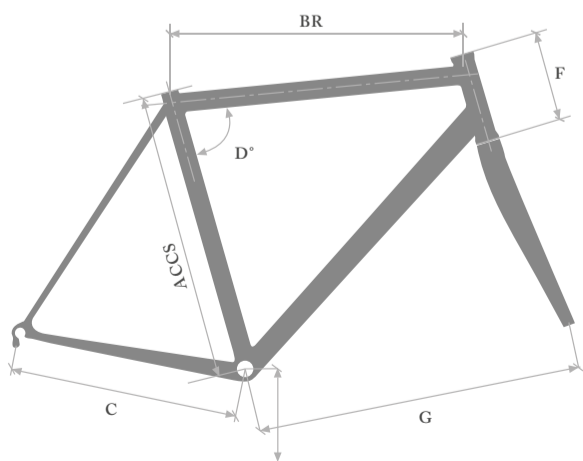

SLOPE ACCS	ACCR <i>cm</i>	BR <i>cm</i>	C <i>cm</i>	D°	F <i>cm</i>	G <i>cm</i>
44	48	51	39.80	76°	104	58
45	49	52	40.10	75°88'	111	58
45	50	52.5	40.10	75°15'	122	58.1
46	51	53	40.20	75°	130	58.1
47	52	53.5	40.40	74°30'	137	58.2
48	53	54	40.45	74°15'	146	58.3
49	54	54.5	40.55	74°	154	58.4
50	55	55	40.65	73°45'	165	58.6
51	56	56	40.85	73°10'	173	59
52	57	56.5	40.90	73°	181	59.2
53	58	57.5	40.90	73°	192	60.2
54	59	58	41.00	72°45'	202	60.4
55	60	58.5	41.00	72°30'	212	60.6

ACCIAIO - STEEL



DE ROSA

ACCIAIO - STEEL

LA LEGA DELLA TENACIA THE LEGACY OF TENACITY

.....
#tenace #classico - #tenacity #classic
.....

L'elemento che ha caratterizzato la rivoluzione industriale per Ugo De Rosa nel 1953 significa l'inizio di una solida tradizione. La capacità di resistere alle deformazioni e la resistenza alla fatica rendono l'acciaio una materia prima che supera moda e tendenza.

La metamorfosi, nel segno dell'innovazione, sta nelle congiunzioni lavorate a mano, nella saldatura fillet brazed, nella Tig.

Acciaio italiano, per telai italiani e biciclette uniche figlie del cuore.

The raw material that defined the industrial revolution was the beginning of what is now a third generation tradition for Ugo De Rosa and his family.

The tensile strength of steel and its ability to withstand the rigors of the road and the elements creates a timeless reverence for steel frames that supersedes fashion and trends.

The innovations in steel frame building are brought to us in the beauty of the welds, in hand worked joints, in Tig and brazed welds. The care required in the creation and development of a De Rosa steel frame allows us to describe them as daughters from the heart.

NUOVO CLASSICO

IL MUST HAVE THE MUST HAVE

.....
#materico #congiunzione - #steel #classic
.....



Il lusso della bicicletta su misura, che come l'abito dal taglio sartoriale ha uno stile che fa della distinzione il suo biglietto da visita. L'acciaio è protagonista di un progetto esclusivo che si costruisce intorno a ogni estimatore del dettaglio.

Perché la materia si vede e si sente. Sfiare il bordo della congiunzione genera un brivido, che ha il sapore della tradizione, è deciso, forte e determinato.

Sono tre i colori, tra i quali l'inconfondibile Blu Ugo, tutti cromo velati.

The change is immediate. The intake of breath and the word "steel", offered with reverence and in hushed tones; that is what happens when a cycling aficionado sees the **Nuovo Classico**. Strength, determination and tradition are the words that describe the Nuovo Classico steel frame, a made to measure for cyclists of discerning taste who appreciate classic styling and exclusivity. Those who appreciate steel frames move their hand gently over the micro-fuse welded joints and the hand finishes and shudder, simultaneously joyful and incredulous at having found a work of art on two wheels. **Nuovo Classico** is offered in three distinct colors including the unmistakable Ugo Blue.



| SPECIFICHE TECNICHE | TECHNICAL SPECIFICATIONS |

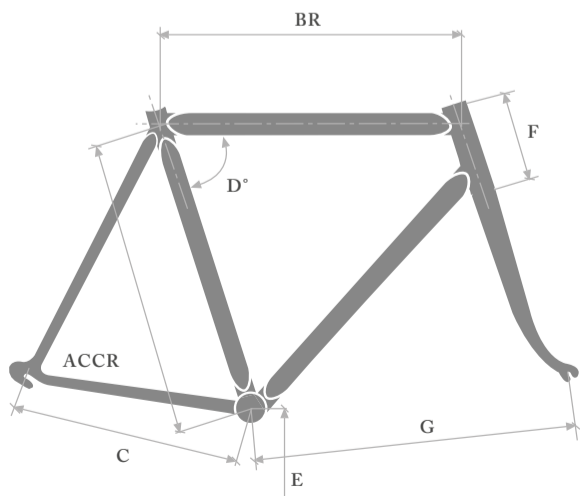

ACCR <i>cm</i> *	BR <i>cm</i>	C <i>cm</i>	D°	E <i>cm</i>	F <i>cm</i>	G <i>cm</i>
48	52	40	75°30'	26.5	8.2	57.5
49	52	40	75°30'	26.5	9.2	57.5
50	52.5	40	75°15'	26.5	10.2	58
51	53	40	75°	26.5	10.9	58
52	53.5	40.3	74°30'	26.5	11.9	58
53	54	40.5	74°15'	26.5	12.6	58.2
54	54.5	40.7	74°	26.5	13.6	58.4
55	55	40.7	73°50'	26.5	14.4	58.6
56	56	40.8	73°10'	26.5	15.3	59
57	56.5	40.8	73°	26.5	16.3	59.4
58	57.5	40.8	73°	26.5	17.2	59.7
59	58	40.9	72°50'	26.5	18.2	60
60	58.5	41	72°45'	26.5	19.2	60.3
61	59	41.2	72°30'	26.5	20.2	60.8

ACCIAIO - STEEL

Âgé

D'ACCIAIO SOLO NEL NOME A DISTINCTION IN STEEL

.....
#stilysh #senzalimiti - #stylish #limitless
.....



Elegante e raffinata fa centro nel cuore dei ciclisti new-romantic. L'estetica, la tradizione e il gusto per il tratto rétro si antepongono alla prestazione. Âgé è caratterizzata dalla saldatura filled brazed che permette la costruzione di un telaio senza l'utilizzo di congiunzioni.

L'occhio è gratificato dall'armonia di una silhouette omogenea: le sezioni dei tubi nei punti di giunzione sono raccordate in modo uniforme e continuo risultando al tatto un unico corpo. Nessuna barriera, nessun limite di spazio e tempo che vengono enfatizzati dalla nuova gamma colori.

A special style of welding called fillet brazing allows for the creation of a steel frame without showing welded joints. This distinction attracts the romantic cyclist, the cyclist who loves the timelessness of steel frames with sleeker, more modern aesthetics. Like all De Rosa steel frames all that is required is one look and the cyclist's heart is captured in perpetuity. In that one look the eye is rewarded by the harmony of a homogeneous silhouette. The sections of the tubing at the joints are connected in a uniform and continuous manner resulting in a single body. The new color range offered for the Âgé add to its limitless nature.

 DE ROSA



| SPECIFICHE TECNICHE | TECHNICAL SPECIFICATIONS |

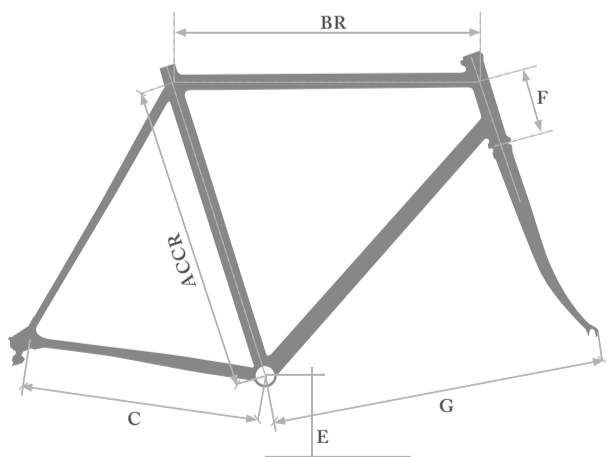

ACCR	BR <i>cm</i>	C <i>cm</i>	D°	E <i>cm</i>	F <i>cm</i>	G <i>cm</i>
48	52	40	75°30'	26.7	8.4	57.5
49	52	40	75°30'	26.7	9.2	57.5
50	52.5	40	75°15'	26.7	10.2	57.8
51	53	40	75°	26.7	10.9	58
52	53.5	40.2	74°15'	26.6	11.9	58
53	54.5	40.5	74°15'	26.6	12.6	58.2
54	55	40.7	74°	26.6	13.6	58.4
55	55.5	40.7	73°45'	26.6	14.4	58.6
56	56.5	40.8	73°30'	26.6	15.3	58.8
57	57	40.8	73°15'	26.6	16.3	59.2
58	57.5	40.8	73°	26.6	17.2	59.6
59	58	40.9	73°	26.6	18.2	59.8
60	58.5	41	72°45'	26.6	19.2	60.3
61	59	41.1	72°30'	26.6	20.2	60.8

Corum

DOVE OSA LA PERFORMANCE IS SHE THE LONE VOICE?

.....
#visione #speedmaster - #madetomeasure #designedforspeed
.....



É lei l'acciaio saldato a Tig, per la coppia che s'incontra alla perfezione. É lei la parte più racing della lega meno morbida. É lei l'eccesso e la tecnologia che si spinge oltre. É lei la visione futura che diventa realtà oggi.

É lei che permette all'acciaio di plasmarsi con misure e dimensioni studiate per chi vuole la velocità costruita in maniera artigianale.

É lei la voce fuori dal coro.

Is she the steel TIG-weld joint that meets perfectly? Is she the racing part of the softer alloy in the fork? Is she the technology that goes further?

Is she tomorrow's vision come true today?

Is it she who allows the steel to merge perfectly with sizes and dimensions designed for those who want speed with a frame built in the traditional way?

Is she the lone voice?



| SPECIFICHE TECNICHE | TECHNICAL SPECIFICATIONS |

ACCR	BR <i>cm</i>	C <i>cm</i>	D°	E <i>cm</i>	F <i>cm</i>	G <i>cm</i>
48	52	40	75°30'	26.7	8.4	57.5
49	52	40	75°30'	26.7	9.2	57.5
50	52.5	40	75°15'	26.7	10.2	57.8
51	53	40	75°	26.7	10.9	58
52	53.5	40.2	74°15'	26.6	11.9	58
53	54.5	40.5	74°15'	26.6	12.6	58.2
54	55	40.7	74°	26.6	13.6	58.4
55	55.5	40.7	73°45'	26.6	14.4	58.6
56	56.5	40.8	73°30'	26.6	15.3	58.8
57	57	40.8	73°15'	26.6	16.3	59.2
58	57.5	40.8	73°	26.6	17.2	59.6
59	58	40.9	73°	26.6	18.2	59.8
60	58.5	41	72°45'	26.6	19.2	60.3
61	59	41.1	72°30'	26.6	20.2	60.8

ALLUMINIO - ALUMINUM

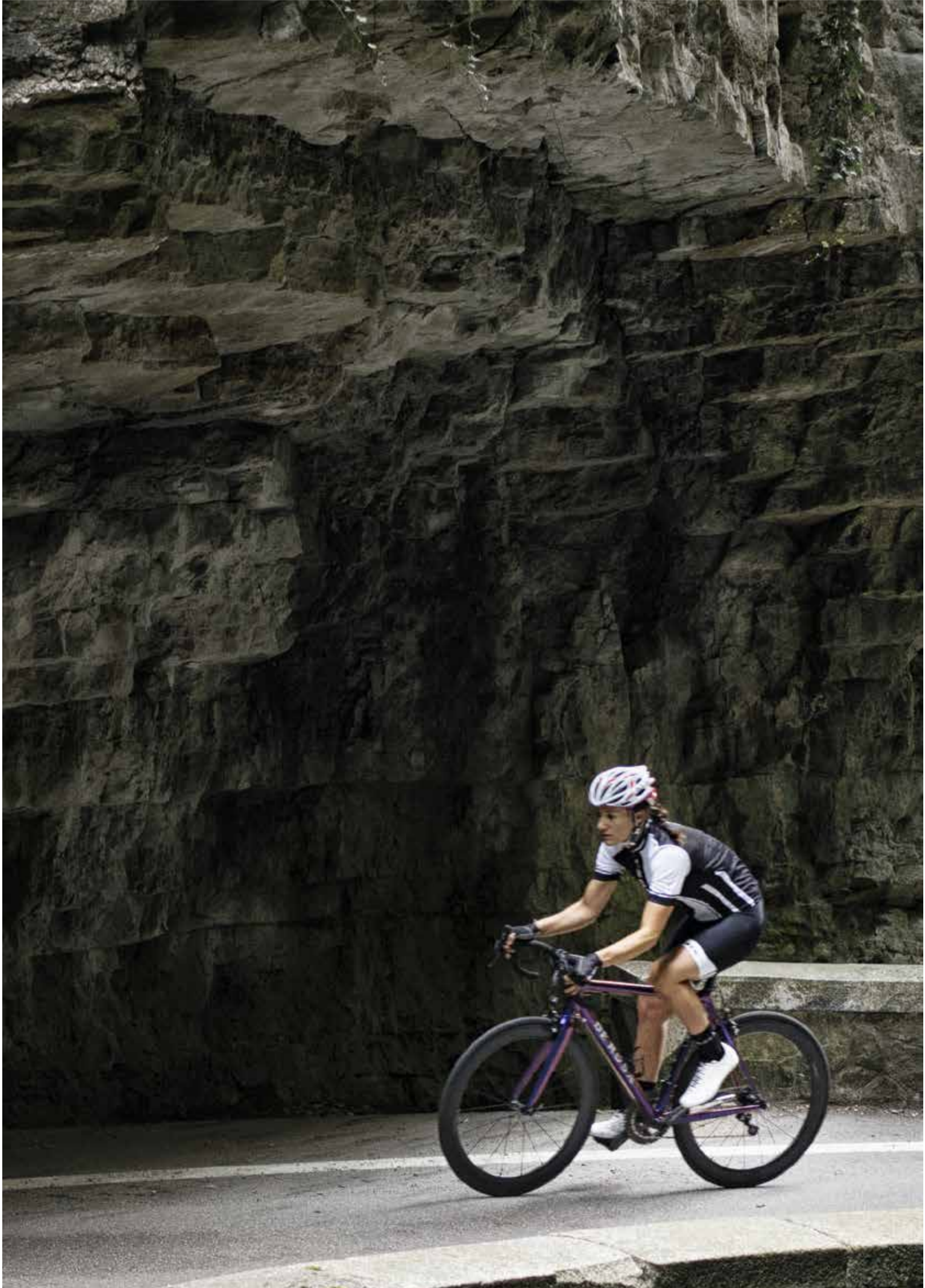

 DE ROSA

ALLUMINIO - ALUMINUM

LA LEGGEREZZA DELL'INTUIZIONE INNOVATION FOLLOWS INTUITION

.....
#leggero #innovativo - #innovation #intuition
.....

La sua leggerezza e la sua resistenza rappresentano la capacità di De Rosa di cogliere le nuove tendenze e farle proprie, con lungimiranza e capacità di rendere unico e nobile ogni prodotto.

L'alluminio è una intuizione di Ugo De Rosa che, nel 1997, ha colto l'importanza di questo metallo e ha dato l'input al reparto ricerca e sviluppo di Cusano Milanino per iniziare a produzione e affinare i telai in questo materiale.

The basic properties of aluminum are lightness and stiffness, seemingly opposites yet both are required in order to create a perfectly balanced frame. De Rosa has a history of perfectly balancing their intuition for finding new materials and developing new processes and merging them into their unwavering commitment to open minded creativity and innovation.

In 1997 Ugo De Rosa intuitively began to sense the benefit of utilizing aluminum in the development of bike frames and committed the company to a program of research and development related to the production of high quality aluminum frames.

SCANDIUM

L'AVANGUARDIA DELLA MODERNITÀ THE VANGUARD OF MODERN DESIGN

.....
#intuizione #avanguardia - #intuitive #vanguard
.....



Alla fine degli anni '90 sul lungomare di Laigueglia, Ugo De Rosa viene colpito dal nuovo trend americano di costruire bici turistiche dal telaio imponente.

L'intuizione è immediata: è necessario aggiornare la tendenza interpretando la cultura italiana votata alla prestazione. Nasce il telaio in alluminio che poi diventa la **Scandium**, una bicicletta dallo scheletro leggero, che si presenta con le stesse prestazioni del carbonio ma più rigido.

Sempre moderna e attuale è l'avanguardia su due ruote.

In the late '90s while visiting the Mediterranean coastal town of Laigueglia Ugo De Rosa saw firsthand the new American trend of building tourist bikes using aluminum road bikes frames. Sig. Ugo intuitively realized the need to capitalize on the trend and improve it by infusing it with Italian design and performance. The aluminum frame was born and grew to become the **Scandium**, a very light frame that matches the performance standards of carbon but is more rigid. **Scandium** is truly the vanguard of modern design and performance in aluminum.



| SPECIFICHE TECNICHE | TECHNICAL SPECIFICATIONS |

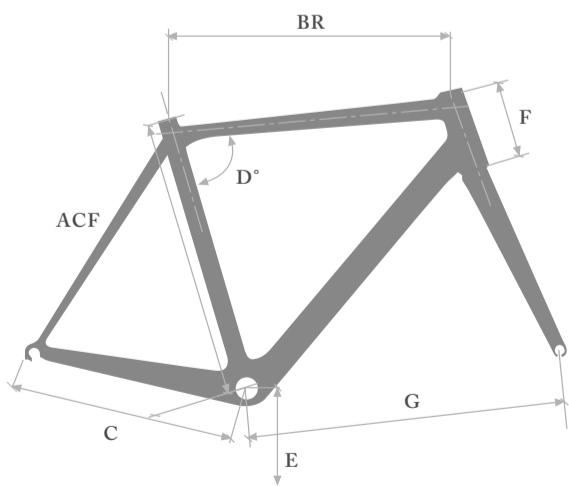

ACF	BR <i>cm</i>	C <i>cm</i>	D°	E <i>cm</i>	F <i>cm</i>	G <i>cm</i>
45 slope	52	40.5	75°	26.8	12.8	57.5
46.5 slope	53.5	40.5	74°50'	26.8	13.2	57.7
48 slope	54.5	40.7	74°30'	26.8	13.7	58.1
49 slope	55.5	40.7	74°	26.8	14.5	58.6
52 slope	56.5	41	73°	26.8	16.5	59
54 slope	57.5	41	73°	26.8	18.4	59.5
58 regolare	58.5	41.2	72°50'	26.8	18.4	60
60 regolare	60	41.2	72°50'	26.8	20.5	61





L'IDEA - THE IDEA

UN SOGNO SU MISURA A TAILOR MADE DREAM

Per raccontarvi il progetto Black Label, voglio fare una premessa.

La nostra azienda è italiana. Ed essere italiani è un privilegio, ma anche una responsabilità.

Vi starete domandando cosa significa questa affermazione.

Semplice: dire sono italiano e produco prodotti italiani vuol dire garantire al cliente e all'intero mercato eleganza, qualità, unicità. Tutte caratteristiche coordinate da un processo creativo completo: dall'idea, al bozzetto, alla realizzazione, al packaging finale con il quale si offre la singola unità.

La cura del dettaglio, l'estro nel design, il connubio tra forma e funzione reso possibile dalla tecnologia applicata per il miglior risultato possibile rendono un prodotto italiano unico. Se migliore, lo diranno i volumi. Ma sulla diversità non ci sono dubbi.

Questo discorso è valido nella moda, nella cucina, nell'arredamento, nelle motociclette, nelle biciclette e maggiormente nel lusso, dunque nell'alto di gamma, di ciascuna categoria.

Dire *made in Italy* è essere consapevoli che si sta generando un'aspettativa molto alta nei termini che ho sopra descritto. Un'aspettativa che vuole essere ripagata, che necessita di certezze e garanzie.

È per questo che quando realizziamo le nostre biciclette rispettiamo tutti questi parametri: perché la nostra realtà è italiana e vogliamo essere ambasciatori di eccellenza.

Ma andiamo oltre e accanto all'eccellenza, come vi

In order for me to properly speak with you about De Rosa Black Label it is important for me to provide you with what I believe is important information.

Our company is Italian and for us being Italian is a privilege; with privilege comes great responsibility. Perhaps you are wondering what this means; after all, I am about to discuss our bicycles.

For us it is simply this: to say the words "I am Italian and produce

Italian products" means ensuring the market in general and each and every customer a unique product of great elegance, quality, and style. Each distinct feature is perfectly combined with every other feature throughout the entire creative process - new idea and continuing on to sketch, technical design, manufacturing, final product, packaging and, where applicable, accessories - culminating in a single coordinated product.

The merging of strict attention to detail, bold and creative design, the marriage of form and function made possible by carefully researched

technology applied to achieve the best possible result are the foundational principles in the creation of a unique Italian product. The quality of the products speak for themselves; differentiation is absolutely clear.

This discourse and these principles are true in fashion, food, furnishings, motorcycles, and bicycles; exponentially so in the luxury class of each category.

I believe I have expressed my sense of responsibility as it relates to the use of the words "Made in Italy", and that responsibility is this: to be aware that one is creating a very high expectation in the minds and hearts of the customer and that we must reward and guarantee that expectation with certainty.

We carry this responsibility in our hearts when we make our bikes. Our reality is clearly Italian and we want to be ambassadors of excellence.



accennavo, vogliamo offrire unicità.

Come nella migliore delle tradizioni sartoriali italiane, che confezionano abiti su misura per ogni singola persona, così De Rosa confeziona la bicicletta giusta per la persona giusta.

Realizza il desiderio di avere un'opera d'arte tailor made, con l'attenzione per ogni singolo dettaglio: dalla scelta del materiale, al telaio su misura, alla colorazione, fino alla scelta dei componenti e alla finitura richiesta dal cliente.

Questo progetto si chiama **Black Label** e sotto questa "etichetta" rientrano tutti quei prodotti customizzabili, nei quattro materiali che caratterizzano la nostra storia: acciaio, alluminio, titanio, carbonio.

Black Label è l'idea che ha celebrato i primi 60 anni della nostra azienda. Ed è l'iniziativa che ci ha permesso di sottolineare la nostra artigianalità e la nostra capacità di lavorare 4 elementi molto particolari e con caratteristiche differenti, adatte a differenti tipologie di persone.

.....
ACCIAIO

LA LEGA DELLA TENACIA

ALLUMINIO

LA LEGGEREZZA DELL'INTUIZIONE

TITANIO

LA NOBILTÀ DELLA RESISTENZA

CARBONIO

IL CARATTERE DA DOMARE

.....

Vogliamo essere certi di poter realizzare il desiderio di chiunque voglia distinguersi e raccontare parte della propria personalità anche attraverso una bicicletta studiata e realizzata appositamente.

I nostri "maestri" si dedicano a ciascun progetto con la massima attenzione possibile e la concentrazione che l'unicità merita.

In tutto il mondo non ci sarà mai una bicicletta Black Label uguale ad un'altra, sia esteticamente sia dal punto di vista della performance e delle caratteristiche tecniche, perché ogni Black Label è assolutamente irripetibile.

Cristiano De Rosa

However, offering excellence is not enough for us, as I mentioned earlier we also want to offer uniqueness.

As is true in the best traditions of Italian tailors who make bespoke suits for every single person, at De Rosa we create the perfect bike for each person. Our customer is able to realize his or her desire to have a work of art tailor made to their exact specifications with great attention to each detail. Beginning with the material and a completely custom frame to choosing an exact color and finish, specific components and accessories; with our input and support the customer realizes their dream of owning their perfect bike made specifically for them.

This project is called "**Black Label**".

Under this label we provide all customizable products beginning with the material; Black Label bikes are available in any of the four materials that have defined our history of innovation: steel, aluminum, titanium, and carbon.

Black Label is the idea that celebrated and honored the first 60 years of our company and the initiative that provided us with a platform to highlight our craftsmanship and ability to work with four very distinct elements and materials, each of which is particularly suited for different people.

.....
STEEL

THE LEGACY OF TENACITY

ALUMINUM

INNOVATION FOLLOWS INTUITION

TITANIUM

A TRADITION OF SUPERIORITY

CARBON

BALANCE CREATES PERFECTION

.....

Our goal is to be able to fulfill the desire and dream of any customer who, through the bike that was built specifically for him or her, wants to stand out from the crowd, express their unique personality and divulge the innermost workings of their heart and soul.

Our artisans (mechanics, frame builders, painters, designers, support team) dedicate themselves to each project with the greatest possible attention and concentration to each detail; it is what the uniqueness of each project deserves.

Scour the world and you will never find two people who are exactly alike; this is also true of a Black Label bike. Aesthetically, in performance and in technical specifications each bike has its suchness.

Cristiano De Rosa



MONSIEUR UGO DE ROSA



TREDUECINQUE



SCANDIUM



NICK



IDOL



SK LUXURY



TREDUECINQUE



FORMULA KING



PLANET



NUOVO CLASSICO



KING XS



ÂGÉ



SK H2SPEED



SOLO

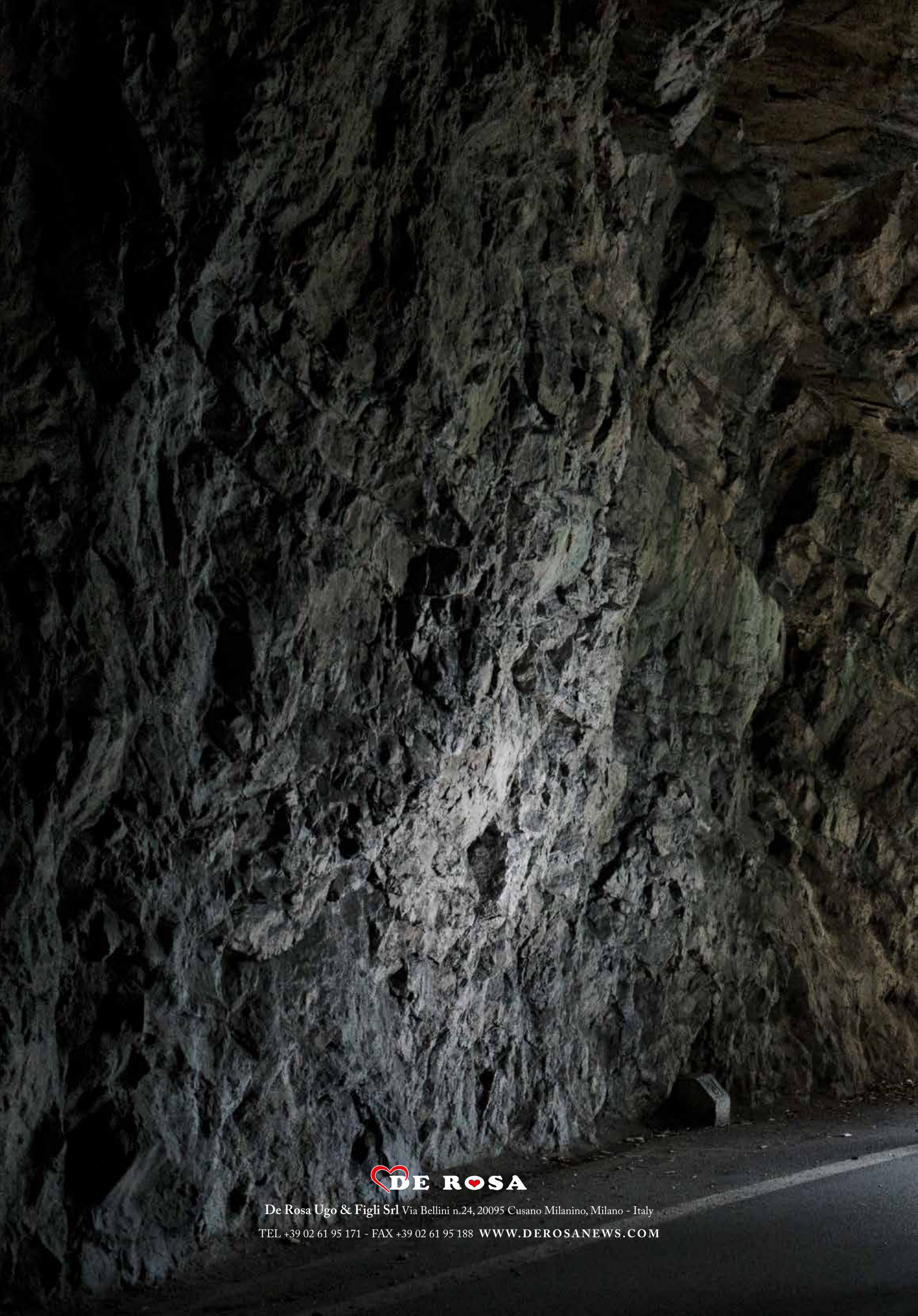

De Rosa Ugo & Figli Srl Via Bellini n.24, 20095 Cusano Milanino, Milano - Italy

TEL +39 02 61 95 171 - FAX +39 02 61 95 188 WWW.DEROSANEWS.COM